

Trends in Fiber Optic Communications

Jan Conradi
Director, Strategy
Corning Optical Communications

2001 ICF Congress, Berlin



Good morning Ladies and Gentlemen,

It is great to be in Berlin again.

My first visit was many years ago, when I took a train from West to East via a number of boarded up railway stations. I emerged somewhere very near this spot, to see the Brandenburg Gate. It is really wonderful to see now what has happened meanwhile!

Now, let us move to the first slide of my presentation.

Outline

- Drivers
 - Bandwidth Demand
- Technology
 - Driver & Enabler
- Summary Outcomes of Technology Evolution

This is about Bandwidth from both a historical perspective, as well as a technology and a service perspective.

- The demand for increased bandwidth, as also explained by Ove Alm, is of course the primary driver today. But there is more to it.
- Back in 1968, at Standard Telecommunications Lab, UK, Kao and Hockham suggested the potential of long distance transmission by using light. The pace at which the physical technology has evolved since that date, has really made technology a driver in the evolution of the network. Particularly in terms of bandwidth evolution. The resulting network capabilities in turn enable economic provisioning of broadband services.
- Also, it isn't just physical technologies such as optical fibers, lasers, and other optical components that form part of the kit of enabling technologies, but we need to consider networking technologies as well.

The Growth in Telecommunication Capacity/Capability

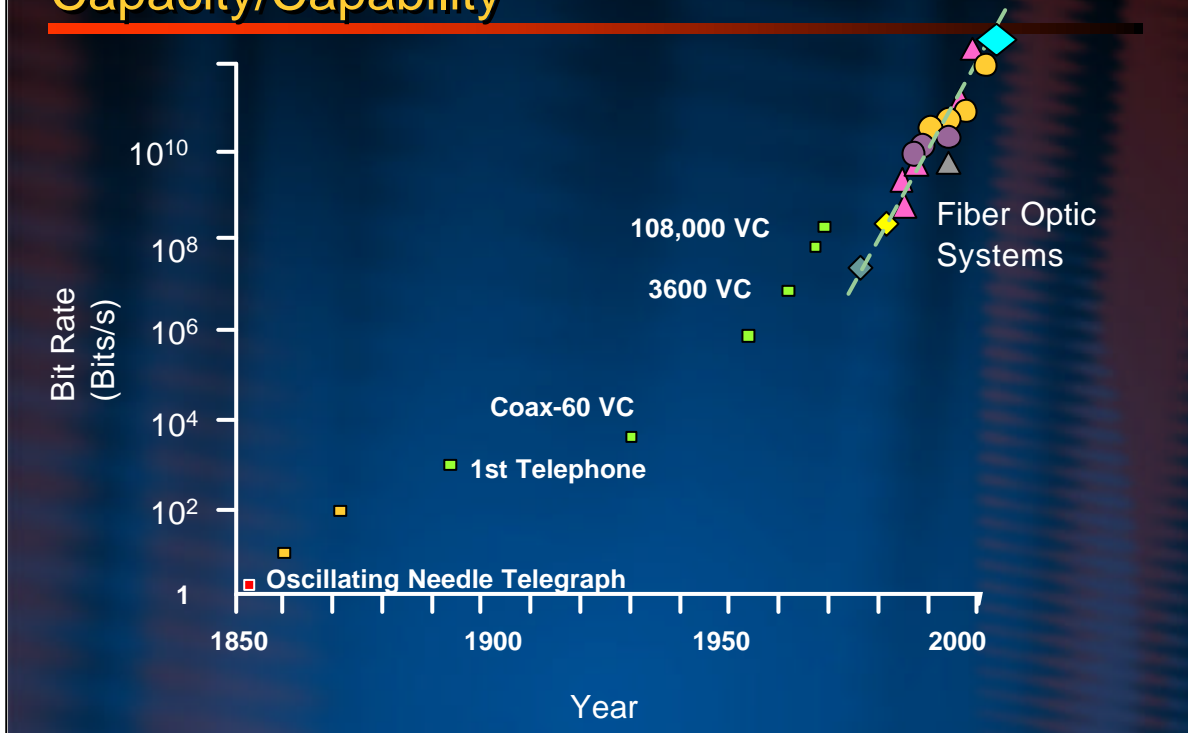

Bandwidth increase has been exponential for a century and a half.

In the very beginning, first telegraphs and the morse code, there was exponential growth to some extent. However I wish to draw your attention to the period 1930 and onwards. The capability of coaxial cable made the telecom capacity grow at an exponential rate, not very much different from what we have seen for fiber optics since about 1975. There were installed coaxial systems by Nortel between Montreal and Toronto, carrying 274 Mb/s on a single coax. So in a broad perspective, bandwidth growth has been exponential through several generations of telecom technologies.

A more focused concentrated perspective starts in 1985 where the early speed increases in optical systems was more due to electronic speeds than anything else. The early fiber optic systems operated at 45 Mb/s on a single fiber increasing progressively to 135 Mb/s, and 565 Mb/s prior to the introduction of SONET and SDH; then to 622 Mb/s, 2.5 Gb/s, and 10 Gb/s.

The optical amplifier came along in the early 90's and allowed longer distances as well as more bandwidth by adding a number of wavelength channels that could then be simultaneously amplified.

Slide courtesy of my colleague and co-inventor of the modem fiber - Don Keck.

Demonstrations of Optical Fiber Capacity Growth

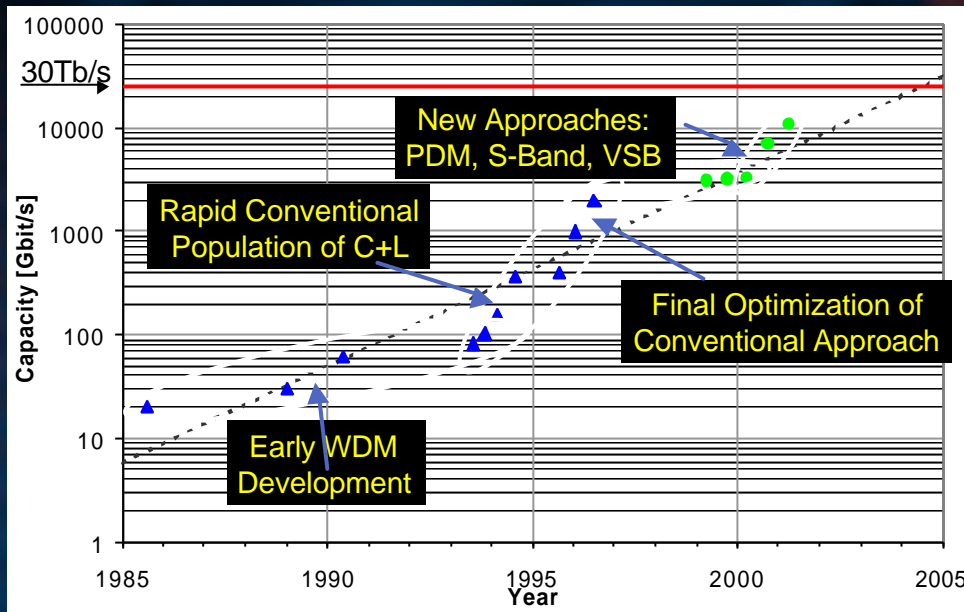

This slide gives the evolution of demonstrations. Commercial availability tends to lag by about 3-5 years.

Top of commercial systems is a 160 wavelengths at 10 Gb/s each.

This illustrates how various technological improvements each gave rise to significant increase in total transmission capacity.

The conventional band or C-band 1532-1565 nm, the Long wave L-band up to ~1625 nm and the Short-wave S-band down to 1420 nm.

The optical people discovered - like the electrical engineers before - that various modulation techniques can be used to improve efficiency. Such new approaches for optics are explored in recent years:

- PDM - Polarization Division Multiplexing (used in satellite transmission) and
- VSB - Vestigial sideband (originating from cable TV).

The red line at the top represents an approximate limit from information theory standpoint for binary signals in the low loss fiber window between 1420 & 1670 nm. That is in the order of 30 Tb/s for one fiber.

USA Traffic Demand Growth

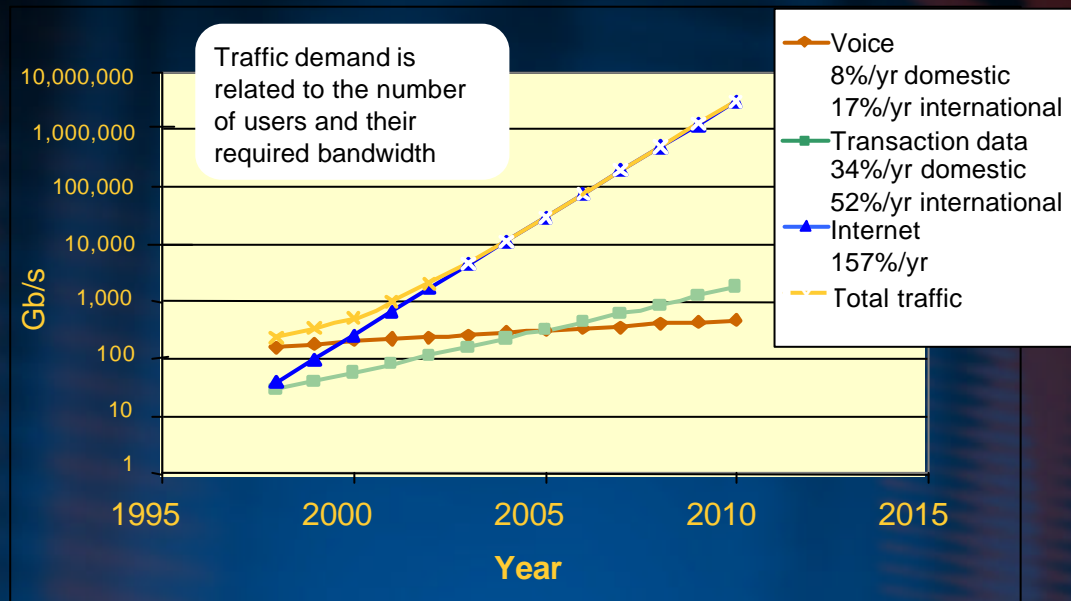

Let's turn our attention to actual traffic demanded of the network as in the USA. This slide on a logarithmic scale is similar to what Ove Alm just showed.

For voice even with the proliferation of cell phones, the growth rate of aggregated voice traffic is still only 8%/yr compared with 34 to 55%/yr for conventional data traffic and then 150%/yr for Internet. This is closely tracked; most recent data is July of this year. No saturation is seen at all for internet traffic. This growth is due to four factors; which when multiplied together gives the rate at which total traffic demand grows: the number of users x a growing number of hosts x the time on line x the bitrate that an individual user has access to. Also here we find that the higher the access bitrate, the longer a user tends to stay on line.

You don't have to be a "rocket surgeon," as a Canadian hockey commentator once said, to realize that Internet is rapidly beginning to dominate.

Similar growth rates exist in other parts of the world, but from different starting points. This means that similar curves develop there but with some what later intersection points.

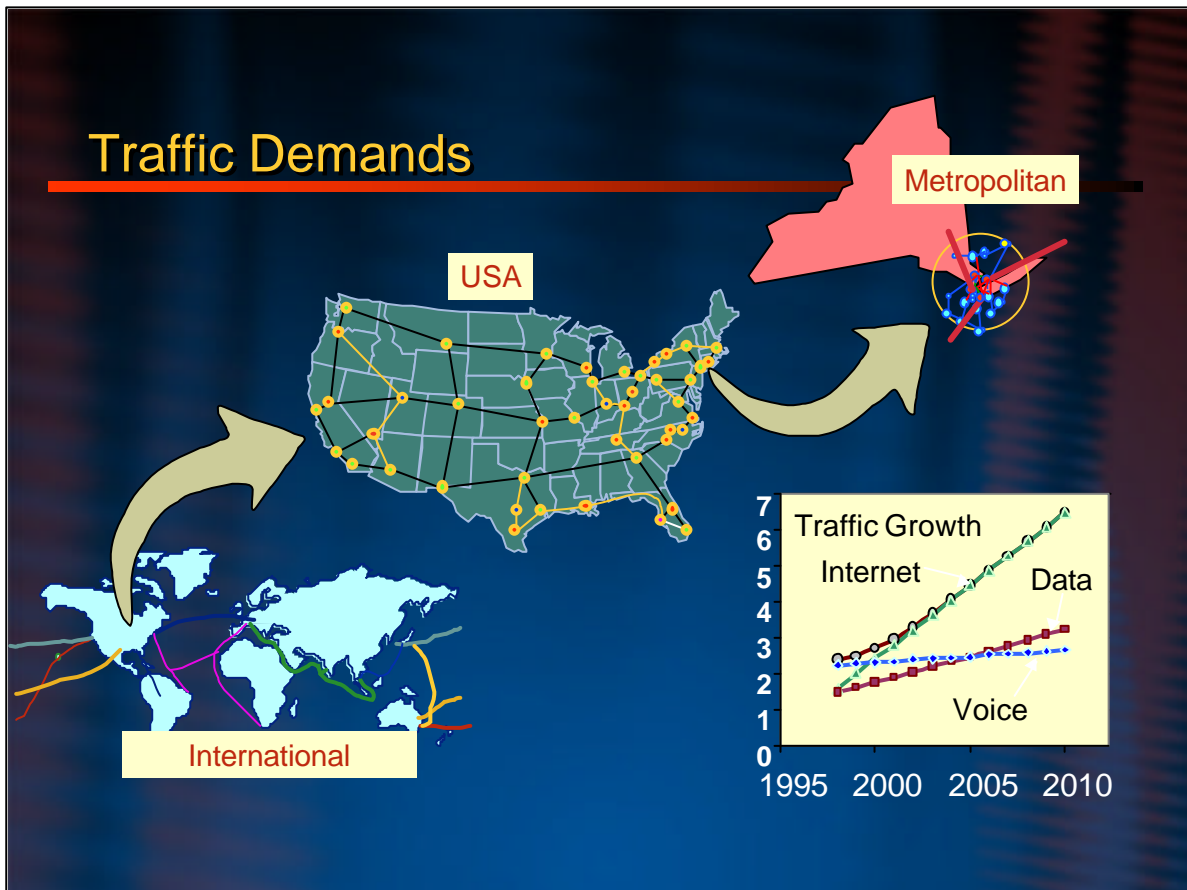

To consider traffic & technology we need to consider how the traffic is distributed over the world wide network.

This slide is a US centric view for which I apologize, but it does illustrate a point.

Voice traffic is usually clustered around metropolitan networks or other relatively small regions - we speak somewhat more to neighbors than to somebody across the ocean.

Corporate or transaction data is a bit more spread out, but limited to clusters where the businesses are established.

Internet data is almost totally diffuse and distance in-dependent.

This has dramatic impact on the nature of the network, where now data calls are almost independent of distance. The traffic growth here is very rapid and the distances are of global nature. That means that the cost and revenue mix is dramatically different for the network operator when compared to voice or conventional data services.

Most of the revenue still comes from the services which are clustered, but most of the costs now come from the demand for long distance capacity. This explains the strong requirement that the costs for long distance communications come down dramatically in order to provide for the growth.

Network Segmentation

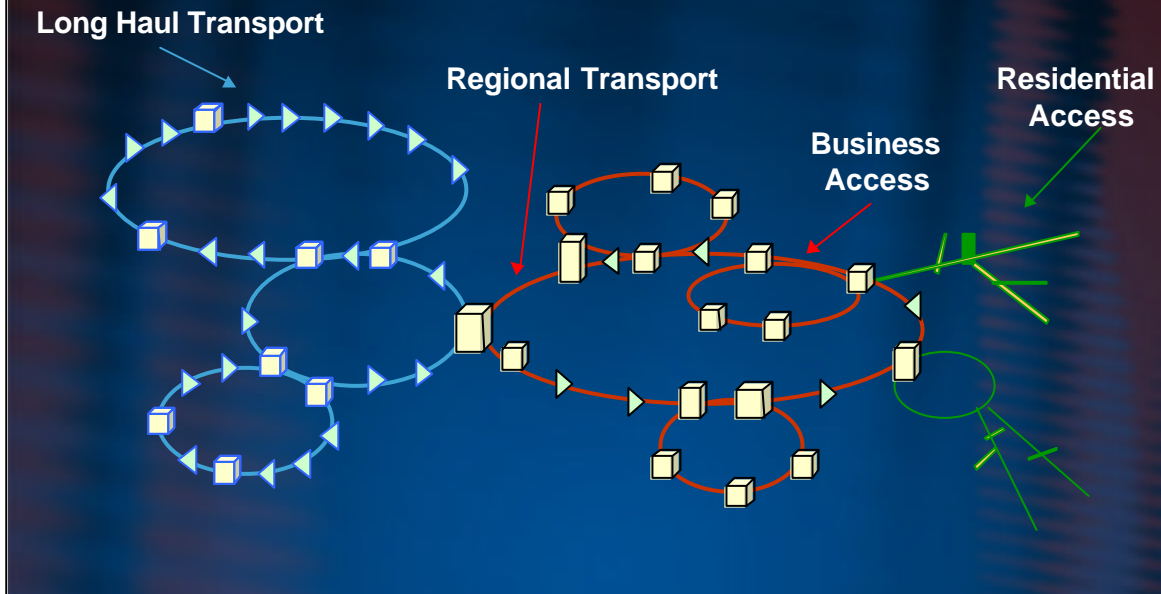

If we break the terrestrial network down to a slightly different level, we can clarify different portions according to their geographic extent.

Today's Network Segmentation

Long-Haul transport

- 200-600 km
- Moving to 3000 km
- 2.5 Gb/s -> 10 Gb/s

Regional Rings

- 200-300 km,
- 2.5 - 10 Gbps

Metro Rings

- 80-100 km,
- 622 Mbps - 10 Gbps

Metro Access

- Shorter distances - 40-50 km
- < 622 Mbps

Engineered for performance:

- Broad band amplifiers (C + L bands)
- Dispersion compensation
- Optical nonlinearity management - LEAF@fiber
- Moderate FEC

Engineered for cost:

- No amplification
- Direct mod. transmitters

Transparency will enlarge and merge today's networks

Each of these network segments has significantly different characteristics:

The long haul was characterized by distances up to 600 km but now moving up to 3000 km, and bitrates of 10 Gb/s now under implementation. The long haul network is the portion that requires most of the new technologies. This part is engineered for high performance as listed, I will come back to the details later.

Regional rings are much shorter, slightly easier to manage.

Whereas the Metro/Access portion is most cost sensitive, the costs of terminal equipment needs a substantial cost reduction.

So each of these segments needs a different optical technology, designed and implemented for most economic performance.

Enabling Technologies

- Optical Amplification
 - Erbium Doped Fiber Amplifier (EDFA)
 - Distributed Raman Amplifier
- Wavelength Division Multiplexing
- Forward Error Correction
- Optical Switching/Networking

These are the most enabling, recent technologies on which today's and tomorrow's networks are being built.

The Erbium doped fiber created a revolution in the late 80's. It is almost like an ordinary fiber but in the core we put a small amount of the element Erbium. The Erbium can be excited or pumped by external light. If we would put mirrors at both ends, the erbium fiber would be a laser. (Light Amplification by Stimulated Emission of Radiation).

Recently the Raman amplifier emerged. In this amplifier very high levels of optical power are actually sent down the transmission fiber in the opposite direction of the signals. By a non linear effect the fiber is converted from a lossy medium into an amplifying medium. This adds considerable flexibility to system designers. Both types of amplifiers (Erbium and Raman) work over a wide range of wavelengths allowing economic application of WDM (Wavelength Division Multiplexing).

Forward Error Correction is borrowed from radio. It enables to extend the reach by a factor 2 to 4. This is a major advance, allowing very long distance optical links without conversion of the light down to electrical level.

“Old” Lightwave Systems

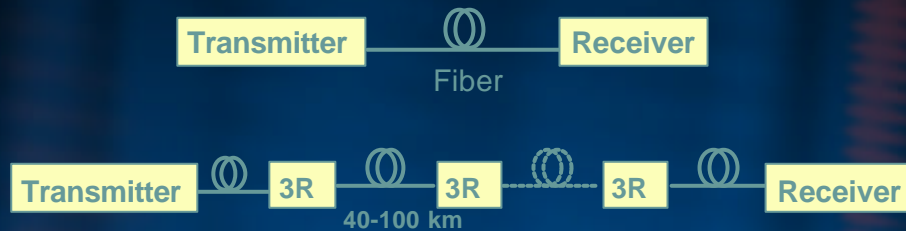

Limitations:

- ◆ Speed of electronics → system capacity
- ◆ Transmitter power and fiber attenuation → transmission distance

Electronics speed and the speed at which lasers could be turned on and off limits the capacity of a single channel.

A signal can travel only a limited distance, then it must be recovered or regenerated. At this distance we need to convert the signal from optical to electrical, re-amplify the electrical signal, reshape the digital bits and retransmit the signal by using another laser. This is a 3R regenerator: to Re-amplify, Re-shape and Re-transmit. The equipment is expensive, is needed for every channel in the system and the speed is limited by the electronics or the laser. The distances between such stations are defined by the power of the transmitter and the attenuation of the fiber.

Fortunately, the distance at which this needs to be done is maximized because we operate at wavelengths where modern fibers have their lowest loss as illustrated on the next slide.

Fiber Types Have Evolved to Maximize System Performance

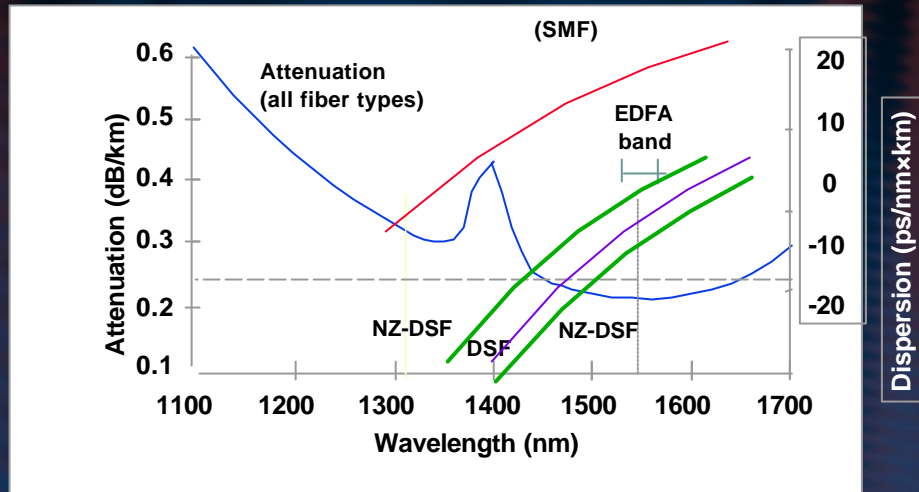

This chart illustrates that the blue loss curve is generally valid for all fiber types. The minimum loss is at 1550 nanometers, very fortunately corresponding with the range of the Erbium doped fiber. Here, for a change, nature works with us.

The green lines give the so called dispersion. Light at different wavelengths travels down the fiber at different speeds. A difference in wavelength of 1 nanometer, causes at a distance of 1 km a difference in arrival time of approximately 17 picoseconds for standard single mode fiber (SMF). This causes pulse distortion, or pulse spreading, and definition of the signal deteriorates. This can be compensated by sections of fiber with an inverse dispersion character.

From this one might be tempted to conclude that zero dispersion would be beneficial. This is the case for single wavelength systems, but for multi-wavelength or wavelength division multiplexed systems some residual dispersion is beneficial which is illustrated by the two curves labeled NZ-DSF which corresponds to Corning's LEAF[®] fiber and MetroCor[™] fiber.

Multiple Wavelength Networks

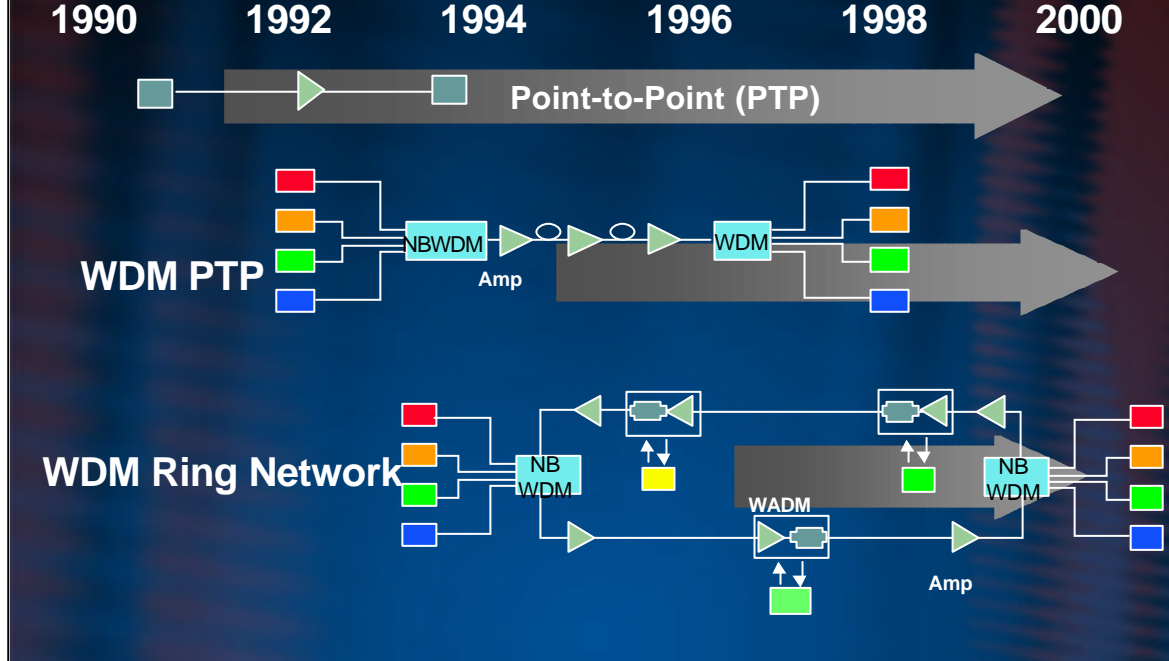

- On top: Single Channel Point To Point (PTP)

The optical amplifier, specifically the Erbium-doped-fiber amplifier, replaced the 3R electronic regenerator and extended the distance between regeneration in a single channel point-to-point configuration.

- Center: Wave Division Multiplex PTP

This same device also can amplify many wavelengths simultaneously and this allows the total carrying capacity to be increased also in a point-to-point configuration.

- Below: WDM Ring

More recently other optical elements are being placed inside these amplifiers such that we can drop and add wavelengths, and this enables optical networking as illustrated by this ring network. In fact this add/drop technique is an analog device.

The so called "Hero result", for an experimental set-up was 256 channels at 40 Gb/s, making a total of 10 Tb/s in one fiber.

Amplified Fiber Systems

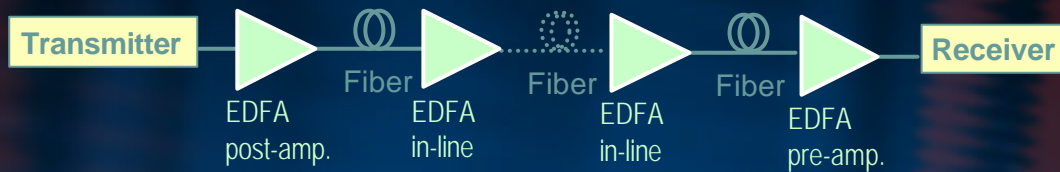

Advantages

- ◆ High speed capability
> 40 Gbit/s
- ◆ Multichannel operation
> 100 channels
- ◆ Long distances without regeneration
> 9000 km

Limitations

- Amplifier Noise
- Fiber dispersion
- Fiber nonlinearity

Here we quantify the advantages of optically amplified systems.

Also the main physical limitations are listed such as the limitation due to the noise of EDFAs and the non-linear behavior of optical fibers at the high optical power levels needed for long distance transmission.

However, this can be significantly improved if we use another type of optical amplifier in conjunction with the EDFA.

Raman-Assisted Transmission

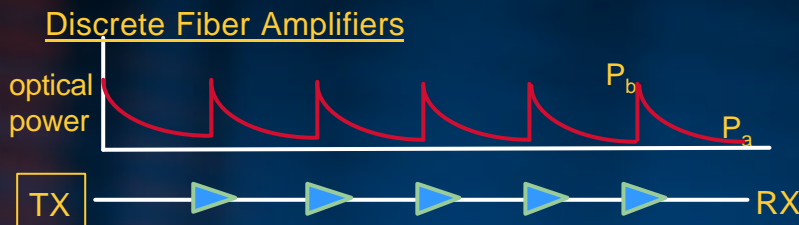

$$Q_{amp} = \sqrt{\frac{P_{o, ch}}{Nh n GFB e}}$$

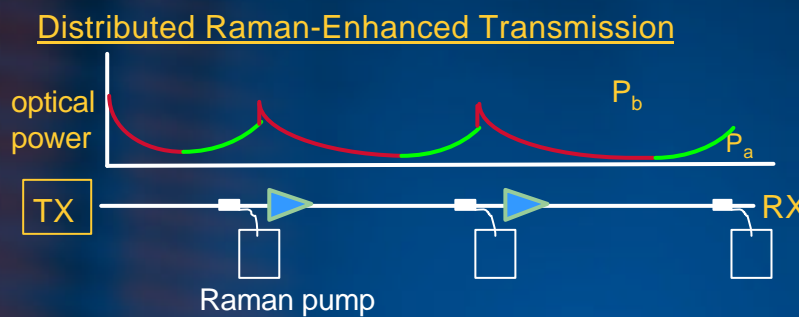

Distributed Raman can be treated as an virtual lumped amplifier

This is the Raman Amplifier. Here, a high power laser or Raman pump is sent in a direction opposite to that of the signal and in fact converts the transmission fiber from a lossy fiber to an amplifying fiber.

In effect we have added another amplifier which allows us to reduce the power per channel launched at the transmitter, which reduces both the overall noise and the non-linear behavior, enabling more than doubling of the distance.

I will spare you the details of the equation, but it should be noted that the optical power of the Raman pumps is sufficiently high that eye safety precautions are needed.

High Data Rate System Schematic

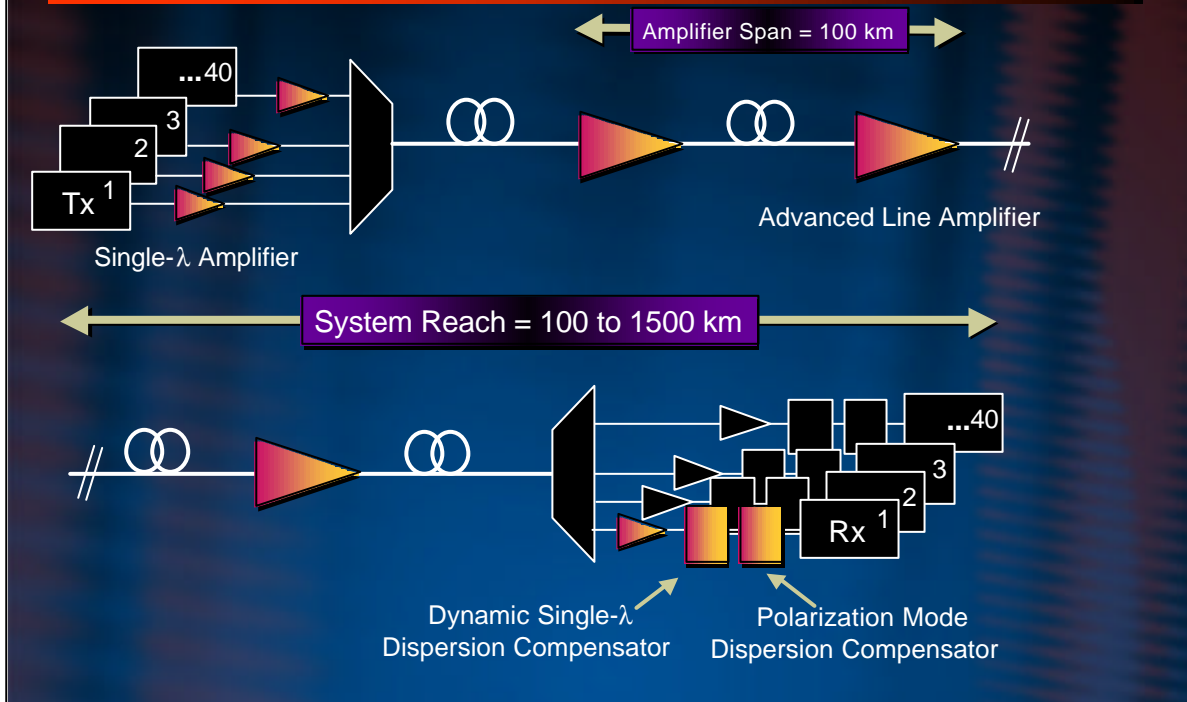

This shows in schematic form all the components of a high data rate system:

Please note that today the system reach is being extended from 1500 km up to 3000 km

- Single optical wavelength amplifiers are sometimes needed to boost the signals from the laser transmitter.
- The multiplexer,
- The De-multiplexer
- Compensators at the receiving end

This is needed because with the longer distance come other impairments that need to be corrected - these include:

- Single wavelength dispersion compensation

Dispersion in a certain way also depends on temperature. In very long distances mountains and deserts have to be passed causing temperature differences that require such correction.

- Polarization Mode Dispersion PMD

Perfectly circular fiber would not suffer polarization dispersion. However, it cannot be avoided that fibers are very very slightly elliptical and travel times will be different for light entering the "long" axis or the "short" axis of the ellipse. That has to be compensated for.

Advanced Line Amplifier

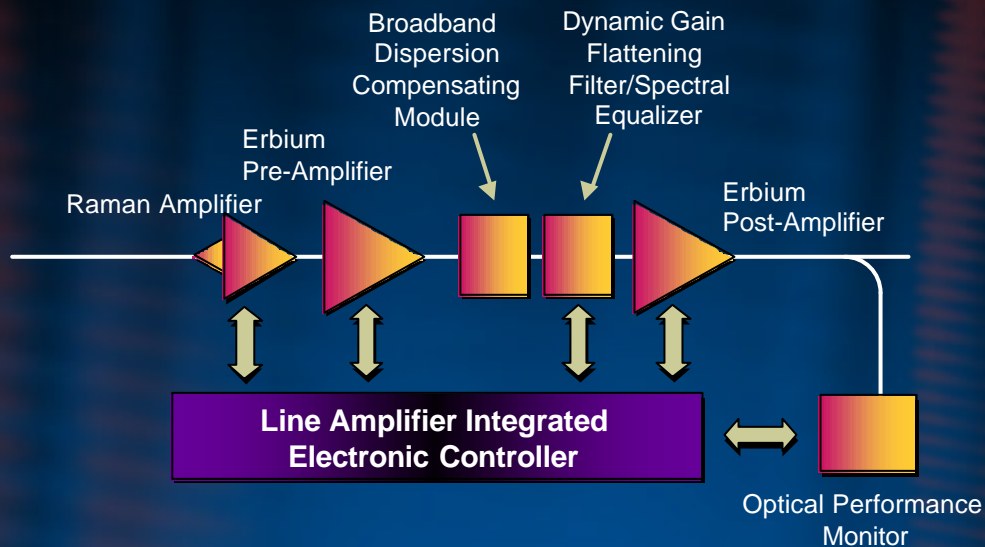

So that the modern optical line amplifier now is a fairly complex piece of equipment consisting of each of the parts shown.

Located between the Pre- and Post- Erbium amplifier are the compensators for dispersion and wavelength dependent amplification. Also channels can be added or dropped. So all in all this has become a fairly complex piece of equipment.

Dispersion Managed Fiber/Cable (DMF/C)

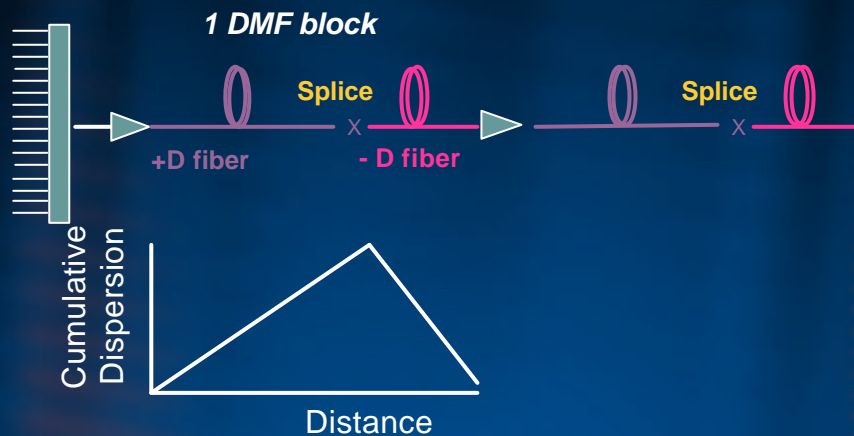

A very recent improvement has been to take out the special dispersion compensating fiber that was incorporated into the line amplifier module and make it part of the transmission fiber in the cable.

This has two advantages -

- 1) The loss inside the amplifier is reduced making the amplifier simpler.
- 2) This fiber is actually quite effective as a Raman amplifying fiber.

From a cable standpoint it does complicate matters as signals travel in both directions, in separate fibers in the cable, and since two fiber types exist in a cable section, we need to be certain that the right fibers get spliced together. Some education of craftsmen will be required as well as proper identification of the particular fibers.

Forward Error Correction (FEC)

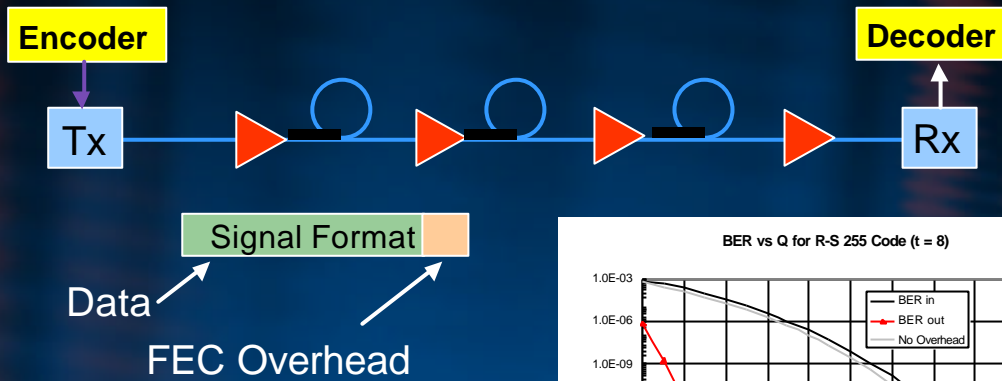

- Redundancy is added to the data
- Allows error detection and correction
- Typical redundancy is 7% or 23%

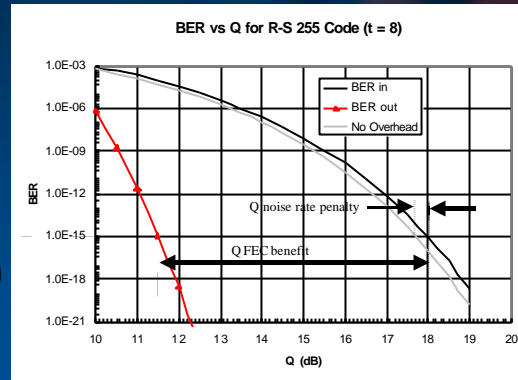

Source: T1X1.5/99-261, Nortel

Figure 1: Example of FEC Benefit and Noise Rate Penalties

The final technology, which has been borrowed from our radio colleagues, is a purely electronic technology called Forward Error Correction or FEC.

System performance is measured by the so called bit/error ratio or BER: the bits that were erroneously detected versus the total number of bits received. The FEC system adds extra bits to the data stream which enables errors to be detected, the concept is highly mathematical.

One bit wrong out of a billion gives a BER of 10×10^{-9} .

Now if BER is plotted versus received power, we see that FEC can give a 6 dB improvement. That is to say that if you squint hard, the same bit error ratio can be achieved with about -6dB or a factor of 4 less power. This is huge in when traded off for additional distance and thus extend reach. A factor four in power can achieve two times longer distance. In principle this now enables transcontinental distances.

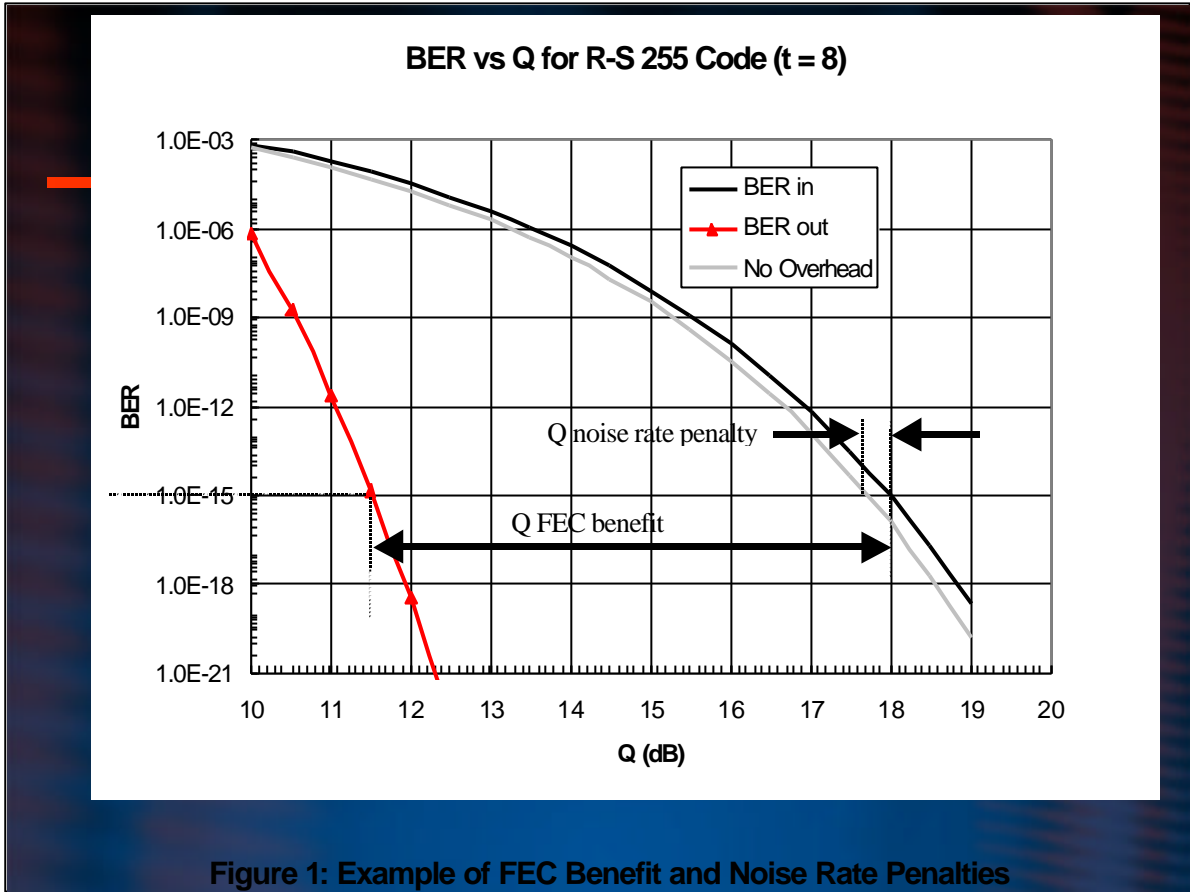
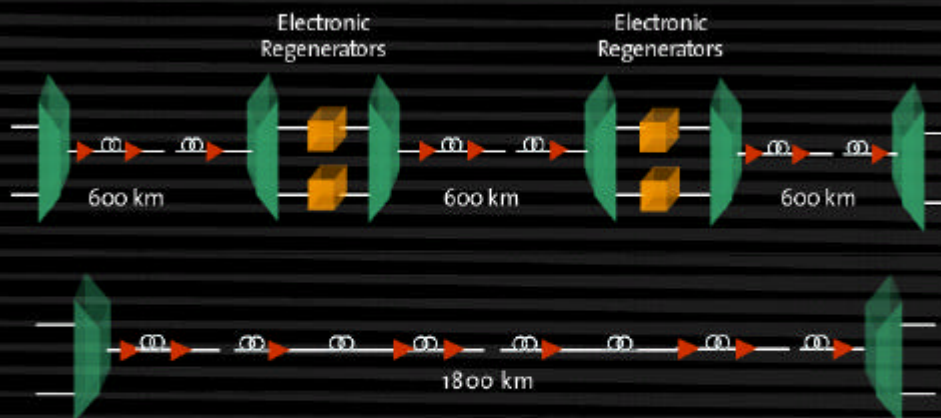

Figure 1: Example of FEC Benefit and Noise Rate Penalties

Enlarged graphics of page before.

Longer...Going Farther Before Needing Electronics



Challenge

How to go farther optically and eliminate expensive electronic regeneration

Fiber Challenges

- Dispersion (Absolute & Slope)
- PMD
- Non-linear effects

So as we eliminate electronic regeneration, which must be done on a channel by channel basis, and replace these electronic regenerators with next generation multichannel optical amplifiers, significant cost savings can accrue.

Value of Long Reach

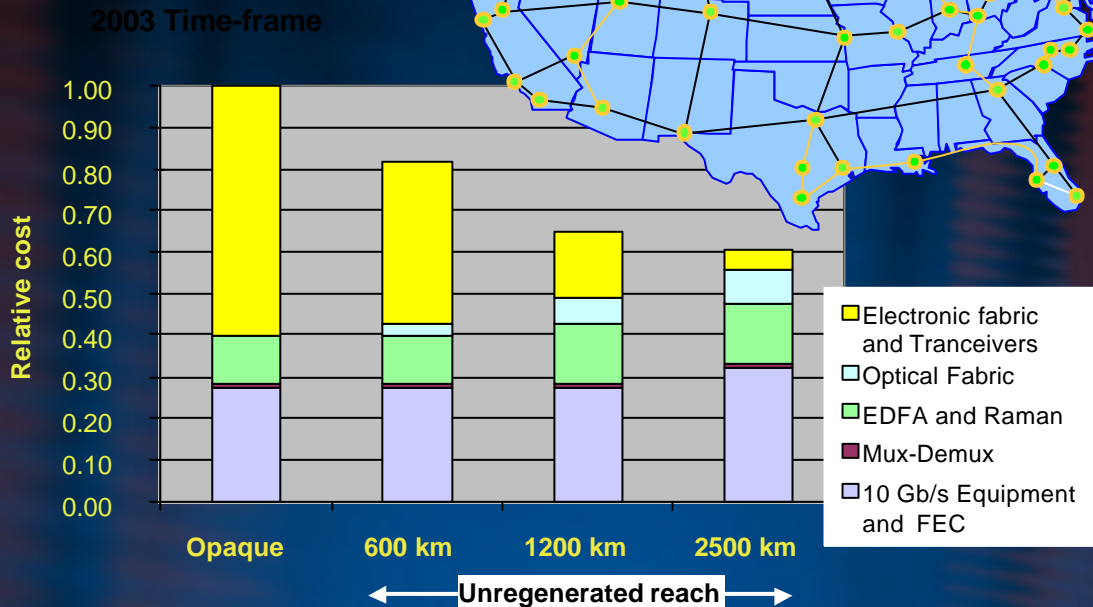

The value of this longer reach is illustrated for a US network where we expect in the 2003 time frame to be able to transmit out to ~2500km. Significant cost savings occur, because of the elimination of electronic regenerators, and this occurs with a slight increase in the cost of the hybrid EDFA - Raman amplifier, as well as FEC.

USA Long-Distance Network



Just to illustrate that this concept doesn't just apply to the USA where the network has 46 nodes or Points of Presence connected by 62 links and a 5000 km East/West, the next slide shows Europe.

Pan-European Network

20 nodes
32 links
3.2 node degree
13 rings, 4.2 nodes
4000 km scale

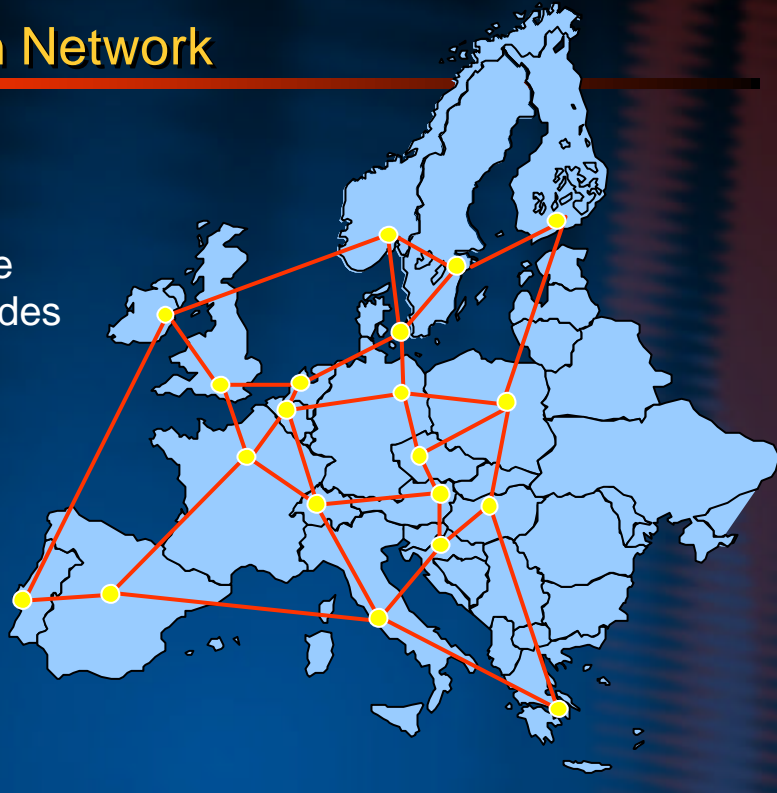

20 nodes over 4000km, and this is not very different. An American way of saying that Europe is not very different from the US....

Comparison of Network Scale

	Scale (km)	Nodes	Node Degree	Rings	Nodes per ring
USA	5000	46	2.7	17	5.2
Europe	4000	20	3.2	13	4.2
NE USA	1500	21	2.5	6	5.5
UK	700	26	2.9	13	4.2
Metro	150	24	2.5	6	6.2

These networks are similar except for scale.

So that the two major western regions of the world have very similar long haul network sizes, while other network segments are similar except for scale.

Smarter...Managing at the Wavelength Level

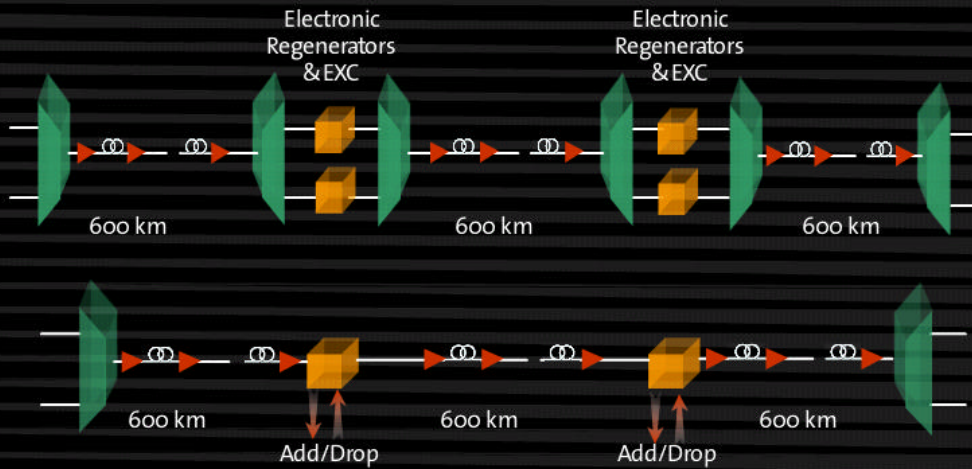

Challenge

How to build transparent networks that eliminate non-value added electronic processing

Fiber Challenges

- Dispersion (Absolute & Slope)
- PMD
- Non-linear effects

To increase network flexibility we can now also build optically transparent networks by including a Wavelength Add/Drop Multiplexer or WADM inside the Advanced Optical Amplifier to create a WDM chain. This allows us to drop a given number of wavelengths at their destination and allow the other wavelengths to pass through optically. Previously this would have had to take place using an electronic router or switch, which we have now eliminated. This property of the all optical network is named transparency.

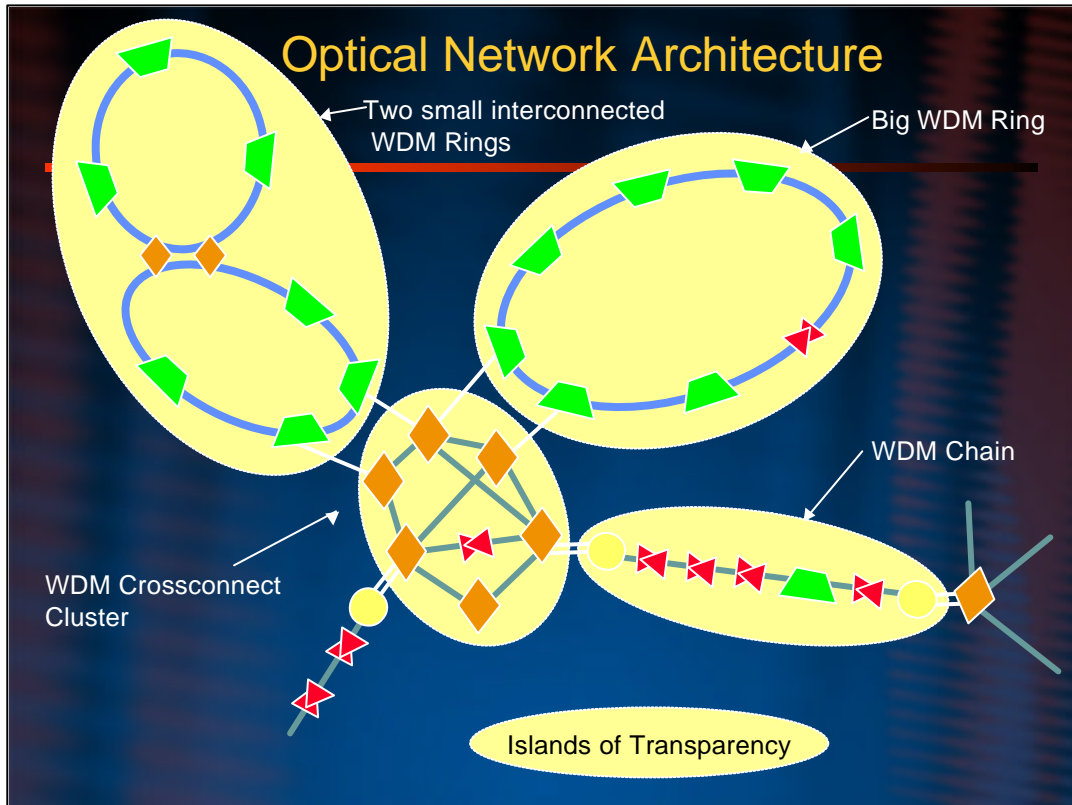

Using WADMs and optical switches called wavelength selective cross-connects or WSXCs, we can create a WDM chain and from that a series of interconnected rings. At the intersections of the rings the WSXC switches selected wavelengths that go from one ring to another.

Value of Optical Routing & Protection

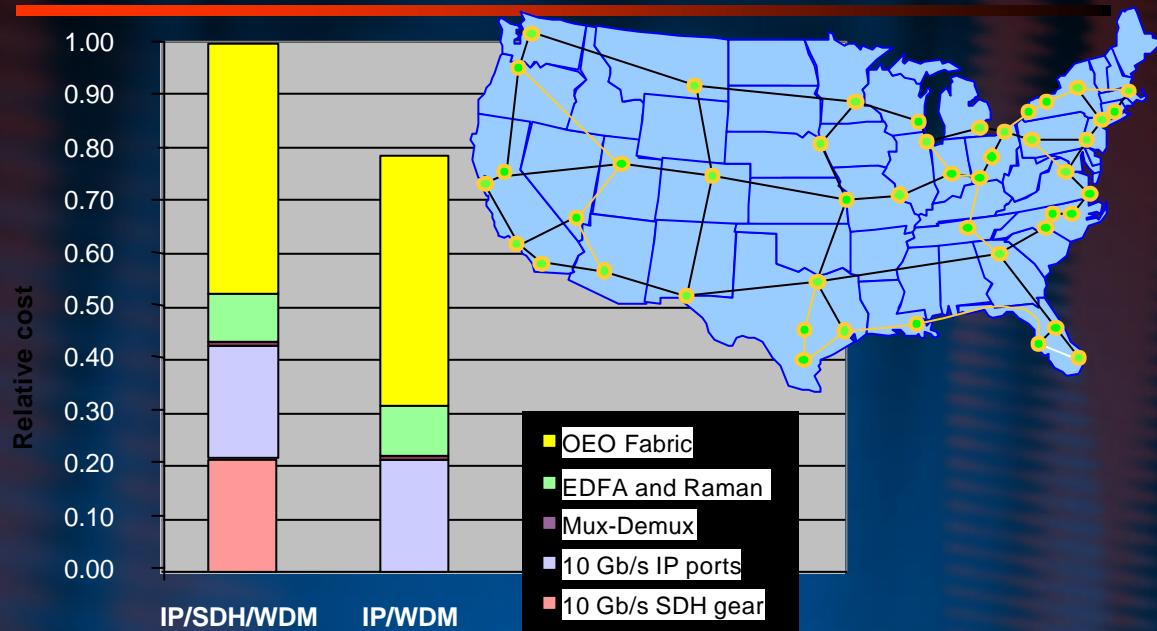

A very preliminary estimate says that the value of such optical routing functions is more than 20% in terms of saving equipment costs. Given time it could be much more on basis of first installed cost.

Value of Optical Configurability

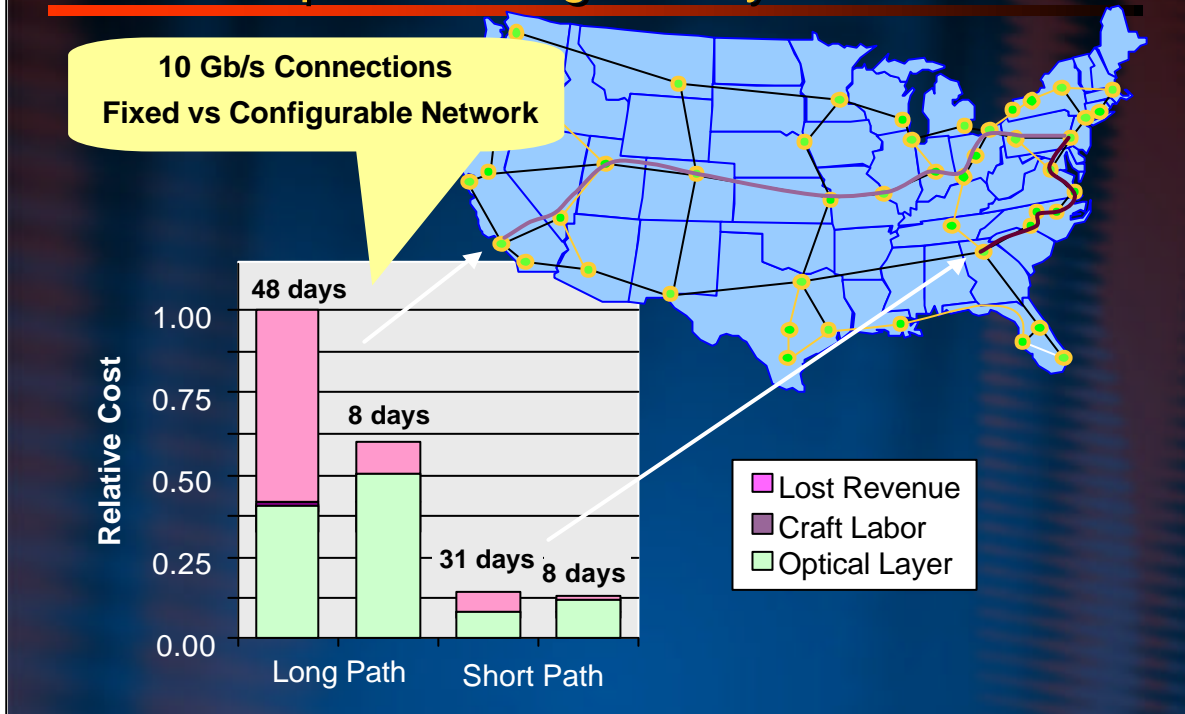

Value of fast provisioning, additional advantage.

Potentially, more important than the savings in first installed cost is the value of being able to quickly configure optical networks with a consequent avoidance of lost revenue due to long provisioning times that are needed to install and configure electronic networks.

Summary Outcomes of Technology Evolution

- Optical Amplification
 - Longer distance transmission with less electronics
- WDM
 - Share fiber and optical amplifiers
 - Huge capacity increases
- FEC
 - Longer distance transmission
- Optical Switching
 - New lower cost networking paradigms
 - Faster more flexible service provisioning

To summarize our technology story:

Optical amplification first allows longer distance transmission with much less electronics,

But the amplifiers are also broadband devices so that they really are the enabler of Wavelength Division Multiplexed transmission which permits huge increases in system capacity and reduced cost through equipment sharing.

Raman amplifiers and FEC then further extend the distances to continental dimensions which when combined with

Optical Switching further lowers network costs and enables future flexible networks with faster provisioning times.

Finally:

Lest We Become Complacent Need for Optical & Electronic Integration

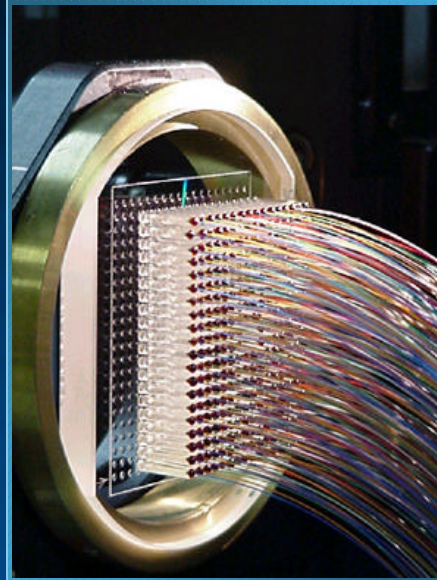

If we are not too complacent about technology reaching an eventual limit, without exaggeration one could state we are at a stage comparable to the first discrete transistors of the 1960's. It took a little while to reach the integrated circuit with millions of transistors on a single chip. At this stage we are nowhere near integrating optical and electrical components on a chip, comparable to today's electronic integrated circuit with its millions of devices.

Hopefully this technology evolution can be achieved.

Thank you for your attention.